

MULTI UP!

MULTI UP 10

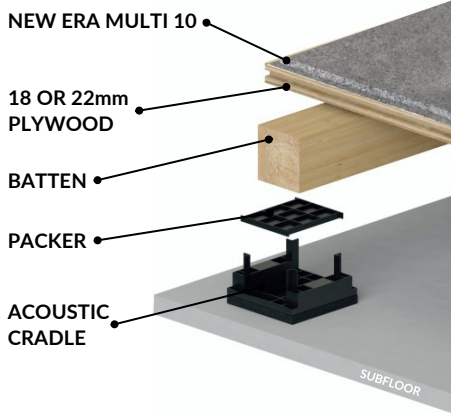

Multi Up 10 is a system that uses the Acoustic cradle and offers a higher level of impact sound isolation, whilst providing lightweight 10mm interlocking recycled rubber tiles, making it an ideal solution for ground or upper level gym and free weight areas with light activities.

Multi Up 10 is a perfect screed replacement option that requires no drying time and can be used instantly after install.

Applications

Renovations
rectify uneven sub-floors
Gyms
Offices
Shops
Schools
Recreation Centres

Features

Easy Loose lay installation
Wear Resistant
Slip Resistant
Shock Absorbent
Recycled Rubber
Easily maintained
Acoustic Properties

Specification

10mm Thick
1000 x 1000mm size
Puzzle lock for easy install
Black or Black Light Grey
PU Binder, Recycled rubber
& Synthetic EPDM
Floor build-up of 82-380mm

MULTI UP 30



Multi Up 30 is a system that uses the Acoustic cradle and offers a higher level of impact sound isolation, whilst providing heavier 30mm interlocking recycled rubber tiles with better shock absorption, also suitable for ground or upper level gym and free weight areas for more impact use.

Multi Up 30 is a perfect screed replacement option that requires no drying time and can be used instantly after install.

Applications

protection of timber floors
Gym studios
Offices
Shops
Schools
Recreation Centres

Features

Easy Loose lay installation
Wear Resistant
Slip Resistant
Shock Absorbent
Comfortable underfoot
Sound absorbent
Recycled Rubber

Specification

30mm Thick (27 + 3mm)
500 x 500mm size
Puzzle lock for easy
install Black or Black Light Grey
PU Binder, Recycled rubber &
Synthetic EPDM, Foam Rubber
Floor build-up 100-380mm

MULTI UP LVT

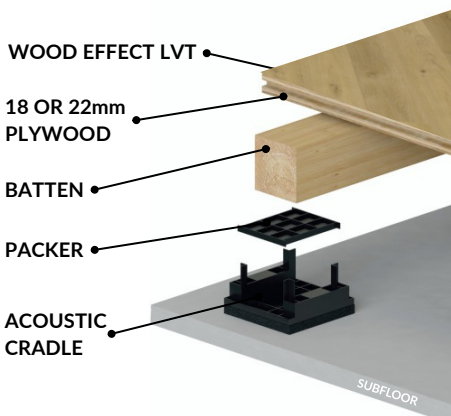

Multi Up LVT is a system that uses the Acoustic cradle and offers a higher level of impact sound reduction, whilst providing a beautiful 5mm wood effect plank LVT floor covering, making it an ideal solution for ground or upper level Studio and multi use areas.

Multi Up LVT is a perfect screed replacement option that requires no drying time and can be used instantly after installation.

Applications

Overlay for existing floors for
quick and easy renovations
Spin Studios
Fitness Suites
Home/Office
Schools
Shops

Features

Water Resistant
Stain Resistant
Slip Resistant 36+ PTV (Wet)
Scratch Resistant

Specification

5mm Thick
(0.55mm wear layer)
Width 190mm
Length 1230mm
Floor build-up 76-380mm